

1.0 Megapixel Color High Definition IP Camera

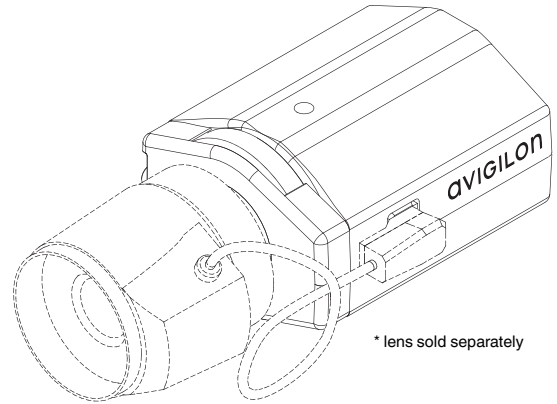

From Puls Limited
www.puls-ltd.co.uk

Description

The Avigilon 1.0 megapixel color high definition IP camera is a progressive scan CMOS camera designed for a wide range of surveillance applications. It transmits images over 100BASE-TX or gigabit Ethernet using advanced JPEG2000 progressive compression technology to achieve the lowest network bandwidth and most efficient image storage in the industry while maintaining unsurpassed image quality.

The camera's advanced image acquisition system automatically adjusts the exposure time and the iris to ensure all available evidence is captured throughout the full range of day and nighttime scenes. The camera supports C or CS mount lenses and DC-drive auto irises.

The camera seamlessly integrates with Avigilon Control Center NVMS and High Definition NVRs using standard network equipment creating a network based surveillance solution with unmatched performance, ease of use, and ease of installation. Camera power is provided by either Power over Ethernet, 12 VDC, or 24 VAC.

Features

- 1.0 megapixel progressive scan CMOS sensor
- Unsurpassed image quality
- 39 images per second at full resolution
- 61 dB true dynamic range
- 0.2 lux minimum illumination
- Lossless JPEG2000 compression
- 1/3" optical format
- Automatic exposure control and DC-drive auto iris control
- Compatible with C and CS mount lenses
- Adjustable lens back focus
- Power over Ethernet, 24 VAC or 12 VDC power input
- External I/O and RS-485 interface
- Automatically obtains IP address and connects to Avigilon Control Center NVMS

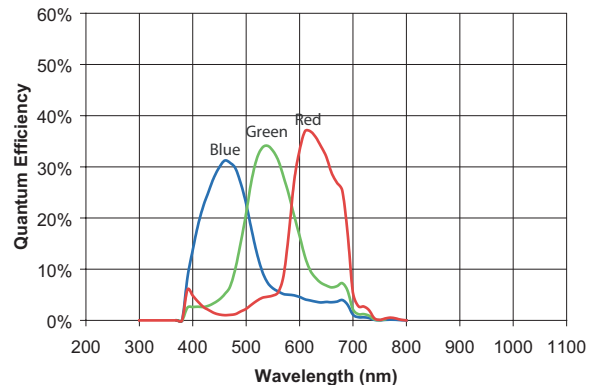

Specifications

Camera

Image Sensor	1/3" progressive scan CMOS
Active Pixels	1280 (H) x 720 (V)
Imaging Area	4.1 mm (H) x 2.3 mm (V) 0.162" (H) x 0.091" (V)
Minimum Illumination	0.2 lux (at F1.4)
Dynamic Range	61 dB
Lens Mount	CS
Image Compression Method	JPEG2000
Image Rate	39 (at full resolution)
Resolution Windowing	Down to 640 x 480 Window
Motion Detection	Selectable sensitivity and threshold
Electronic Shutter Control	Automatic, Manual (2 to 1/60000 sec)
Iris Control	Automatic, Manual
Flicker Control	50 Hz, 60 Hz
White Balance	Automatic, Manual, 6 modes
External I/O Terminals	Alarm In, Alarm Out, RS-485

Bandwidth

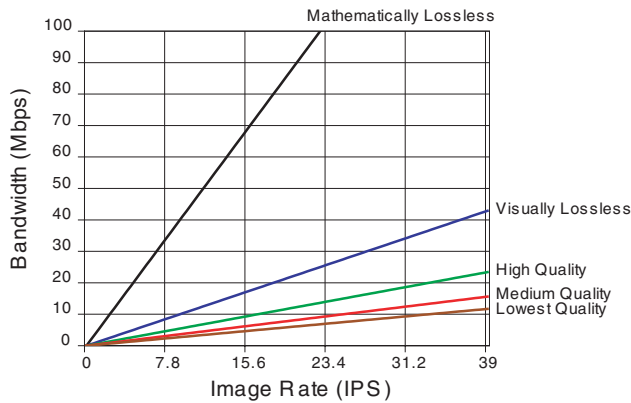

Outline Dimensions

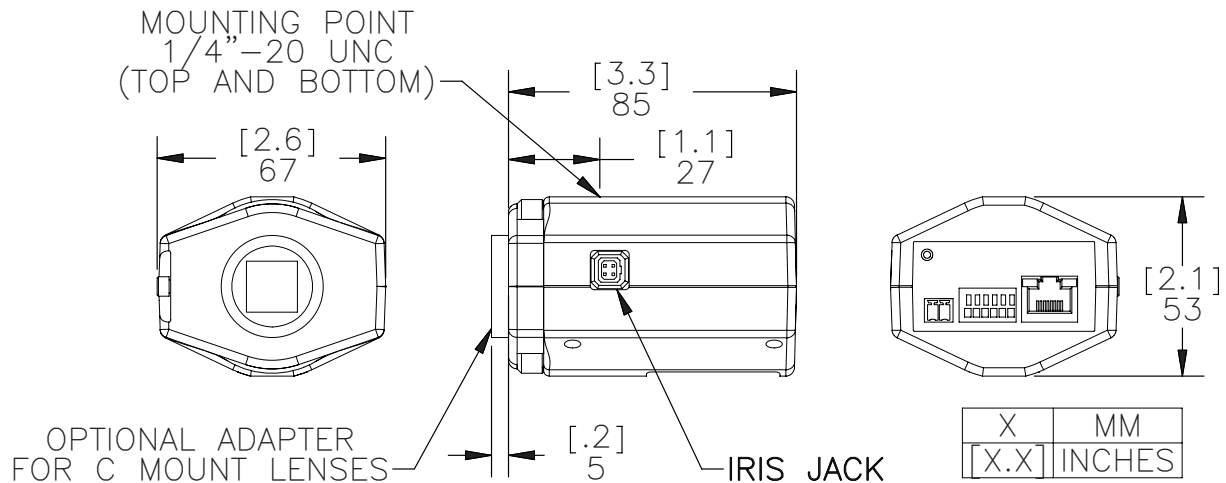

Network

Network	100BASE-TX, 1000BASE-T
Cabling Type	CAT5, CAT5E (for 1000BASE-T)
Connector	RJ-45
Security	SSL
Protocol	UDP, TCP, SOAP, DHCP, Zeroconf

Mechanical

Dimensions (LxWxH)	85 mm x 67 mm x 53 mm 3.3" x 2.6" x 2.1"
Weight	0.53 kg (1.2 lbs) without lens
Camera Mount	1/4" UNC-20 (top and bottom)

Electrical

Power Source	VDC: 12-24 V VAC: 12-24 V PoE: IEEE802.3af Class 3 compliant
Power Consumption	6 W
Power Connector	2-pin terminal block

Environmental

Operating Temperature	-10 °C to +50 °C (14 °F to 122 °F)
Storage Temperature	-10 °C to +70 °C (14 °F to 158 °F)
Humidity	20 - 80% Relative humidity (non-condensing)

Certifications

CE, Class A
FCC, Class A

Ordering Information

1.0MP-HD-C

1.0 Megapixel Color High Definition
IP Camera